



Liquids to Value



T.VIS[®] Feedback Systems

GEA Tuchenhagen Valve Information System

Made by GEA Tuchenhagen



GEA Mechanical Equipment / GEA Tuchenhagen

T.VIS® the GEA Tuchenhagen Valve Information System . . .

. . . the next generation of valve control sets new standards

GEA Tuchenhagen Feedback Systems M-1 and A-7 combine modern valve design with innovative technology. They stand out by simple concepts for installation, operation and maintenance and thus facilitate operational processes.

The T.VIS® series is the optimal solution for the constantly increasing demands made on control systems in modern production plants. The use of T.VIS® series helps the user reliably to lower operating costs.



. . . appears in a modern design

The T.VIS® Feedback Systems (M-1 and A-7) are of standardised appearance that conforms to highest hygienic demands. The modern, for outside cleaning optimised design enhances the process safety as it also fulfills the requirements of high protection classes (up to IP67).

Hosings as previously used on feedback systems are no longer needed, because the T.VIS® Feedback System supplies the actuator that is responsible for the main stroke of the valve with compressed air via an internal pneumatic system.

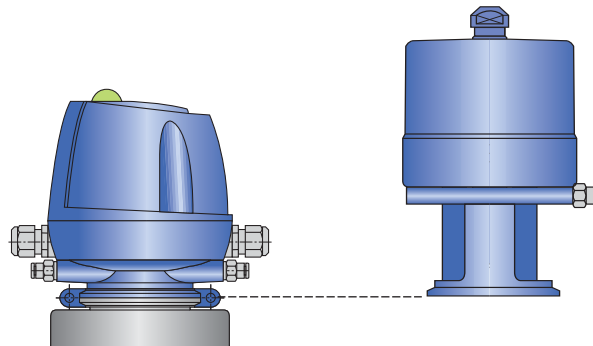

Existing process systems equipped with VARIVENT®, STERICOM® or ECOVENT® Valves can be up-graded to T.VIS® without any problems.

. . . shows clearly the valve status

T.VIS® Feedback Systems (M-1 and A-7) are equipped with a large-sized optical round flashing indicator on the top of the T.VIS® control module. Multicolour light emitting diodes show the user clearly from afar the current state of the valve! Depending on the valve type, the following states can be signalled:

- Non-actuated position (green)
- Actuated position (yellow)
- Seat lift activated (on double-seat valves) (green/yellow slow flashing)
- Request for maintenance (red flashing)
- Error (red)
- LEFF® function active (yellow/green quick flashing)



... is tailored to customers' requirements

Multiple requirements made on components and control systems demand flexible feedback technology that responds to individual customers' requirements by tailored solutions. This is an ambitious aim that T.VIS® Feedback Systems fully meet!

The T.VIS® series integrates two different systems for feedback of the valve position.

The T.VIS® A-7 is a feedback system of the next generation with innovative path measurement technology. The intelligent technique of this feedback system reduces not only the expenditure for installation, operation and maintenance, but significantly lowers the operating costs by use of the LEFF® Function!

T.VIS® M-1 equipped with the proven sensor module combines all advantages of this technology with the advantages of the T.VIS® design.

In this way the T.VIS® series responds to the different customers' requirements and offers optimal solutions.

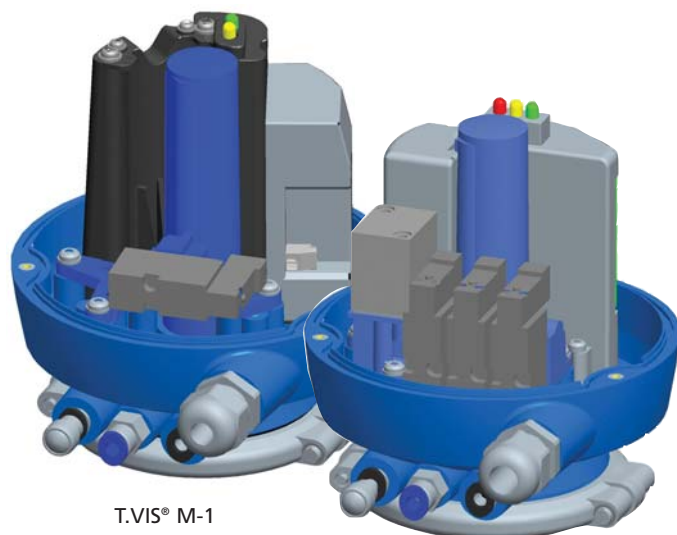

T.VIS® M-1

T.VIS® A-7

... reacts with flexibility

The modular structure allows in addition the two system variants for flexible equipment of the feedback system in order to fulfil individual requirements (e.g. type of interface modules, number of solenoid valves etc.).

Expansion and modification, e.g. the change from binary data exchange to a bus system are easily achieved by exchange of single modules without the need of exchanging the complete feedback system.

Another prove of flexibility is the fact that existing plant systems which are equipped with VARIVENT®, STERICOM® or ECOVENT® valves can easily be retro-fitted with the T.VIS® Feedback Systems because the connections are the same.

... reduces production downtimes

T.VIS® supports the plant user in minimising production downtimes by an optimised maintenance concept. Accordingly, electric or pneumatic connections at the T.VIS® need not to be disconnected and precious time can be saved in this way.



T.VIS® A-7 the innovative Feedback System . . .

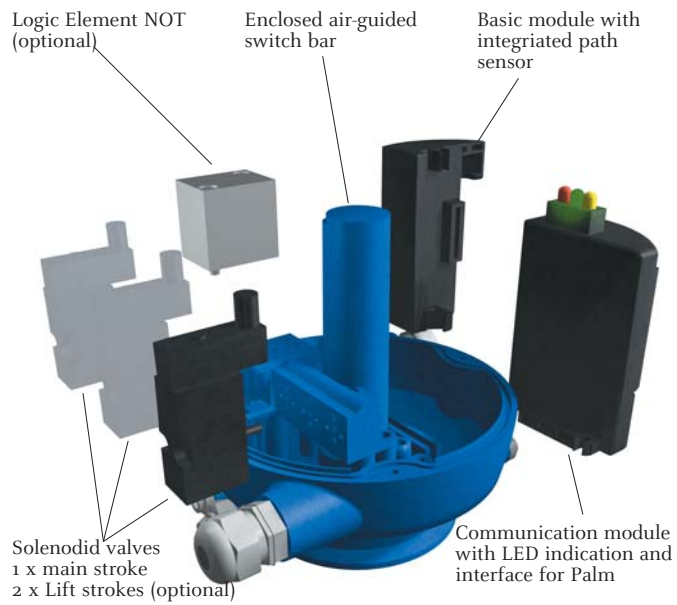

. . . uses state-of-the-art path measurement

With T.VIS® A-7 the customary visual feedback control via sensors is a matter of the past. T.VIS® A-7 uses path measuring technology, the latest technical development in the detection of the valve position.

This innovative method of feedback provides many more advantages for the user. In this way the valve position can be precisely recalled at any time, possible errors are analysed and signalled to the user in the form of flashing LEDs. The LEFF® Function, the use of which leads to significant lowering of the operating costs is integrated as a standard into the T.VIS® A-7.

. . . facilitates commissioning by automatic Set-Up

Commissioning of valves equipped with T.VIS® is extremely easy: The valve takes note of all set switching positions when the button is pressed. In this way, not only the maximum switching positions are activated but also the in-between positions, i.e. the position of the valve disk when activating the lift function on double-seat valves

Thus the time-consuming manual adjustment of the micro switch is a matter of the past and the commissioning work can clearly be reduced. In addition to this, the automatic Set-Up function guarantees an absolutely correct setting of each valve.



Simple valve settings on the push of a button



Manual adjustment is a matter of the past



. . . provides the user with necessary information

The T.VIS® A-7 is equipped with a communication module. Via a serial interface, the user can ask for information and configure the valve.

Using the customary Palm™ Organizer or a Laptop and the software we supplied, you may read-out the most important current valve data directly from T.VIS® A-7. In this way you may - other than with traditional feed-back systems, which read out the non-actuated and actuated position of the valve - at any time identify in addition the current position of the valve stem.

The statistics function recalls additional information about operating duration, number of strokes, time left till the next maintenance routine and length of intervals. If the T.VIS® A-7 is connected to an AS Interface bus system, this data may comfortably be read-out also in the control room.

T.VIS® A-7 the innovative Feedback System . . .

. . . lowers the operating costs by the LEFF® Function

LEFF® stands for „Low Emmission Flip Flop“ and describes permanent pulse switching (opening and closing) of the valve disks during normal lifting operation for cleaning the isolation chamber on double-seat valves

In contrast to the conventional lifting operation with permanently opened valve seat, pulse switching of the valve disks significantly reduces the loss of cleaning media and achieves at least the same good cleaning result.

In this way operating costs which are due to detergent losses can clearly be reduced. (Tests revealed that up to 70% of the losses can be saved by the LEFF® Function). Saving on cleaning solutions means less sewage and practiced environmental protection!

The LEFF® Function is integrated in the T.VIS® A-7 as a standard module.

Advantages of the LEFF® Function at glance:

- Lowers the operating costs
- Protects the environment by lesss sewage
- Without surcharge applicable with the T.VIS® A-7
- Control and error diagnosis of carried out lift strokes

Traditional valve seat lifting with high switching leakage and irregular supply of CIP media to valves connected in series

Using the LEFF® Function during the lifting operation, reduces switching leakage and provides controlled and regular supply of all valves

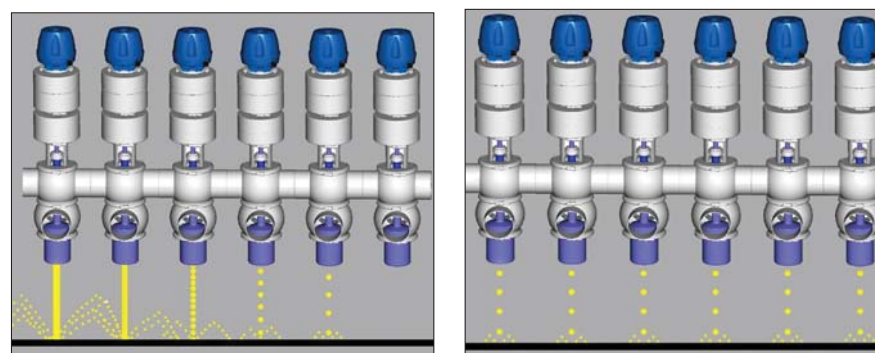

Traditional valve seat lifting

Lifting with LEFF® Function

. . . lowers operational expenditure

T.VIS® A-7 comprises various options that clearly reduce the user's operational expenditure.

Thus maintenance routines and instructions to be carried out according to time windows or number of valve strokes may be entered into the communication module.

Another option with regard to operational expenditure is the integrated diagnosis function. The T.VIS® A-7 signals immediately any errors occuring at the valve by a permanent red light on the top of the control module and ana-lyses the error. The error can then simply and easily be read-out without the need of further cause study.

"Red flashing light":
Service request for
maintenance due

"Red permanent light":
Error indication



Advantages T.VIS A-7

- Innovative, state-of-the-art path measurement
- Automatic Set-Up (manual settings of sensors no longer required)
- Lowers clearly the operating costs of the plant user due to the integrated LEFF® Function
- Reduces significantly operational and maintenance expenditure
- Continuous monitoring of the valve position using the integrated diagnosis system (e.g. monitoring of valve strokes, actuation of solenoid valves)
- Luminous cap for clear and from all sides visible indication of the the valve's current switching position.
- Readout of valve information (e.g. current valve position) and statistics of the valve (e.g. number of carried out valve strokes)

T.VIS® M-1 the proven technology in modern design . . .

. . . uses the proven sensor technology

T.VIS® M-1 stands out by its proven sensor technology. The feedback system contains as an integral part the basic equipment consisting of the 24 VDC interface module, the sensor modules and a pneumatic block.

For AS-Interface and AC supply an easily mountable adapter module is installed upstream the standard interface module.

The logistic advantages of an interconnected basic equipment form the fundamentals for economical efficiency of the feedback system.

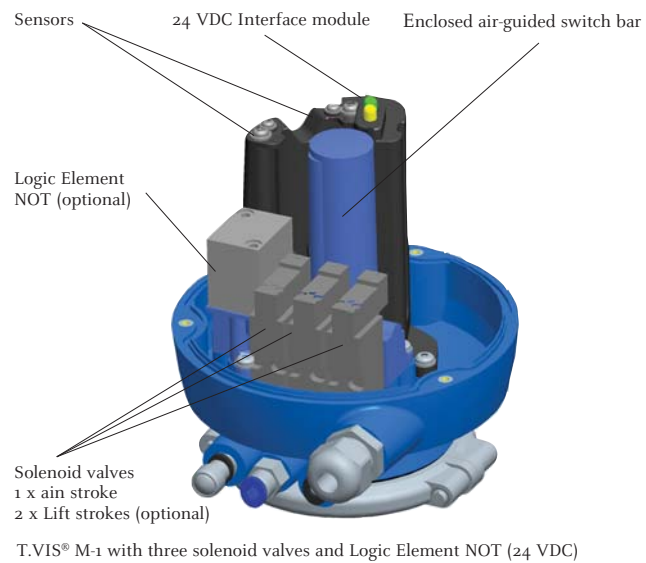

. . . responds flexible to customers' requirements

Flexible equipment of the feedback system with sensors and three solenoid valves maximum allows to respond to specific requirements of the customer.

T.VIS® M-1 offers as an option the connection of a third sensor. This sensor installed in the lantern is used for monitoring the double-disk. In this way the feedback system is most suitable for applications on double-seat valves.

. . . indicates the valve status clearly

The luminous cap on the top of the T.VIS® M-1 shows the user clearly from afar the current state of the valve!

T.VIS® M-1 thus fulfills to the optimum the high standards of modern process technology in the plants of the customers .

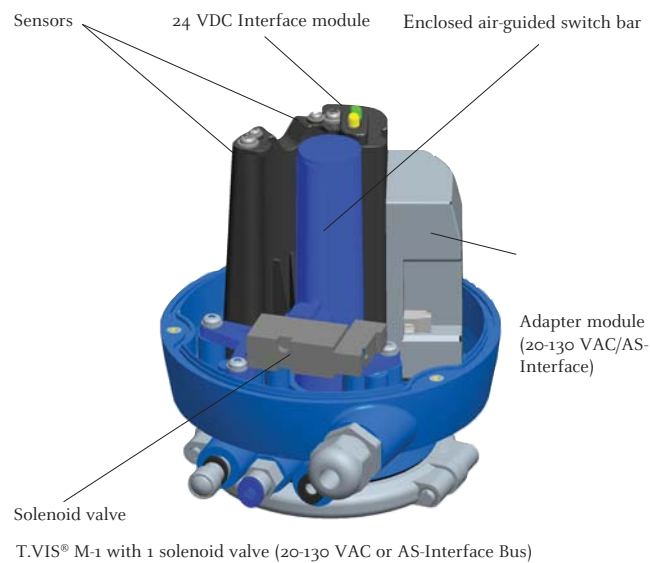

Advantages of the T.VIS® M-1:

- Mature technology
- Economical alternative that give consideration to high demands
- Flexible equipment that repond to the customer's specific requirements
- Modular structure
- Exchangeable for all known GEA Tuchenhagen Feedback Systems
- Luminous cap for clear visualisation of the valve's switching position from afar and from all sides.
- Equipment with three solenoid valves max. and connection of three sensors max.

BUS Technology with T.VIS® the new generation of valve control and monitoring

GEA Tuchenhagen has advanced the T.VIS® technology also for an enhanced use of the widespread AS-Interface Technology.

AS-Interface is the simple, open and worldwide standardised communication system for the Actuator / Sensor Level and is backed-up by interface modules from renowned PLC manufacturers.

By coupling the AS-Interface via gateway to the actual field bus, it supports the field bus to the optimum, but does not replace it.

Information transmission to the control system

Using AS-Interface in the T.VIS® A-7, the communication module transmits all signals via the AS-Interface technology and the field bus to the control system. Thus important diagnostic data and valve information available in the control room can immediately be used for further process steps.



Following information can easily be readout in the control room:

- Start and end position of the valve stroke
- Lift position
- Actual position of the valve stroke
- Time left until next maintenance routine
- Error code for identifying the error
- Number of carried out strokes



AS-Interface vampire contact for the control module ⇨ BUS

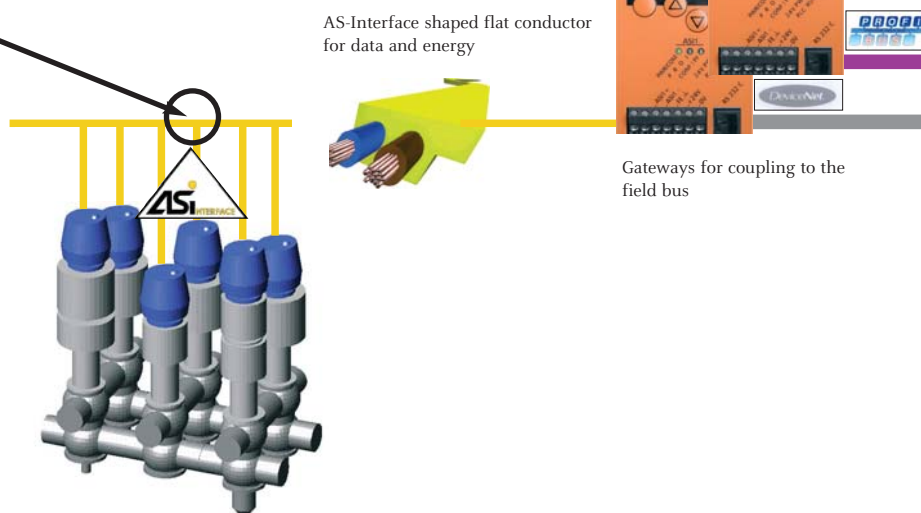

AS-Interface shaped flat conductor for data and energy

Gateways for coupling to the field bus

You are to determine the Master BUS-System !

In most applications a field bus system is used today for data communication between the control system and the field level. The AS-Interface assumes in such applications the lowest level, the so-called Actuator/ Sensor Level. The AS-Interface Master or Gateway serves as a coupling element between the field bus and the AS-Interface wiring system.

The shown system stands out by the following features:

- up to 62 slaves can be connected
- Clear display
- Test of the AS-Interface system possible, also without field bus
- Bus diagnosis
- Field bus coupling for Profibus DP, DeviceNet, CANopen, Modbus/TCP, Ethernet/IP etc.

T.VIS® the GEA Tuchenhagen Valve Information System

Technical features

	T.VIS® A-7	T.VIS® M-1
Feedback system	Path measurement	Interface module and sensors
Settings / Set-Up	automatic	manual
Valve status visualisation visible from afar	yes	yes
Exchangeable for existing GEA Tuchenhagen Feedback Systems	yes	yes
Diagnosis	yes	no
LEFF® Function	yes	no
AS-Interface	yes	yes
Protection	IP66 (IP 67 optional)	IP66 (IP67 optional)

T.VIS® A-7 is available in the following variants:

Number of solenoid valves:

- T.VIS® with one solenoid valve
- T.VIS® with one solenoid valve (prepared for a 2nd and 3rd SV)
- T.VIS® with two solenoid valves
- T.VIS® with three solenoid valves

Interface Module:

- 24 V DC (standard) 3-wire PNP / NPN
- AS-Interface Bus

Feedback via:

- Path measurement
- Equipment with third sensor in the lantern for monitoring the double-disk possible

T.VIS® M-1 is available in the following variants:

Number of solenoid valves:

- T.VIS® without solenoid valve
- T.VIS® with one solenoid valve
- T.VIS® with one solenoid valve (prepared for a 2nd and 3rd SV)
- T.VIS® with two solenoid valves
- T.VIS® with three solenoid valves

Interface Module:

- 24 V DC (standard) 3-wire PNP / NPN
- 48-130 V AC
- AS-Interface Bus

Feedback via:

- 2 Sensors
- Equipment with third sensor in the lantern for monitoring the double-disk possible



GEA Mechanical Equipment

GEA Tuchenhagen GmbH

Am Industriepark 2-10, 21514 Büchen, Germany

Phone +49-4155 49-0, Fax +49-4155 49-2423

sales.geatuchenhagen@geagroup.com, www.tuchenhagen.com

638e-04/2010