

Liquids to Value



T-smart Butterfly Valves

Made by GEA Tuchenhagen



T-smart Butterfly Valves

For many years, GEA Tuchenhagen butterfly valves have proven their worth in process plants with different types of processes.

Under the "T-smart" product label, GEA Tuchenhagen not only offers seat valves but also a butterfly valve series which fully satisfies increasingly higher market demands with respect to functionality, safety and cost-effectiveness.

T-smart butterfly valves are versatile and ensure smooth production processes, whether in production, cleaning or energy management applications in the beverage and food industries, in breweries, in the dairy processing industry or in the pharmaceutical, biotechnological, fine chemicals, cosmetics and health care sectors. What counts are the quality of the final product and the efficiency of the production line. T-smart butterfly valves are pointing the way – the development is based on the latest findings in process technology – in compliance with international standards.

T-smart butterfly valves "Made by GEA Tuchenhagen" are characterized by:

- Improved hygiene
- Optimization (reduction) of switching moments
- Longer seal service life (life-time index)
- New standards with respect to ease of assembly
- Shorter assembly and maintenance times
- Proven GEA Tuchenhagen quality and process reliability
- High cost-effectiveness of production due to longer production uptimes



Classification

A novelty for T-smart butterfly valves is the classification – unambiguously assigned article numbers facilitate the selection and ordering process.

Example - valve code

Art. no.	8	11	1	-	050	1	-	0	0	0	0	-	0	0	0	0
Position	1	2	3		4	5		6	7	8	9		10	11	12	13

8111-	DN	Order number/ Artikelnummer/ Referencia/ Code de commande EPDM
	15	8111-0151-0000-0000
	20	8111-0201-0000-0000
	25	8111-0251-0000-0000
	40	8111-0401-0000-0000
	50	8111-0501-0000-0000
	65	8111-0651-0000-0000
	80	8111-0801-0000-0000
	100	8111-1001-0000-0000
	125	8111-1251-0000-0000
	150	8111-1501-0000-0000

Position	Art. no.	Characteristics
1	8	Valve type <i>T-smart Butterfly Valve</i>
2	11	Connection type <i>welded end</i>
3	1	Pipe class <i>DIN</i>
4	050	Nominal width <i>DN 50</i>
5	1	Material, product contact parts <i>1.4301/304</i>
6	0	Sealing material <i>EPDM</i>
7	0	Type of actuator <i>manual actuator</i>
8	0	Air connection <i>without</i>
9	0	Non-actuated position <i>closed</i>
10	0	Options <i>without</i>
11	0	Inside surface <i>0.8 µm</i>
12	0	Certificate <i>without</i>
13	0	ATEX version <i>without</i>

Design and features

T-smart butterfly valves are characterized by their modular design. Apart from different types of manual actuators, pneumatic actuators in various configurations are also available. The modular design enables easy conversion from manual to pneumatic actuator on site.

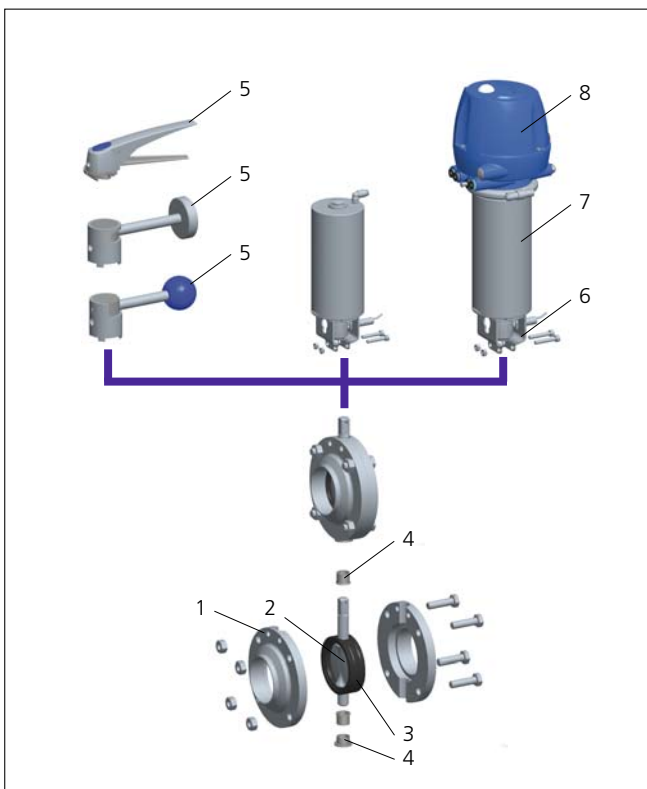

Product features at a glance:

1. Housing flanges with precision-made seal seat geometries
2. Butterfly valve disk, solid forging, with optimized flow characteristics
3. Profile seal in various material qualities, FDA-conform, low switching moment, low wear and vacuum resistant
4. Valve disk shafts run in friction bearings
5. Sturdy manual actuator made of stainless steel
6. Stable holding bracket on both sides to accommodate proximity switches
7. Maintenance-free pneumatic actuator, NC function (alternatively NO)
8. T.VIS® control module (splash-protected) to protect the electrical equipment (optional)

T-smart Butterfly Valves

Core element seal

The most important factor when it comes to achieving maximum functionality is the optimum combination of seal, seal seat geometry in the housing and the butterfly valve disk. Optimum compression in the seal's final assembly state, secure support in the housing, conservation of hygienic properties in the process and minimum wear (even under extreme load) are important factors.

To ensure optimum seal design, FEM analysis (Finite Element Method) was used. On the basis of defined parameters such as material data, geometry and additional basic conditions, static/dynamic calculations were carried out on the model. By graphically representing the calculation results it was possible to visualize strain/stress relationships and other load criteria at different conditions (pressure, temperature, and other process parameters). The FEM results allowed valuable conclusions to be drawn as early as in the development phase, which would otherwise only have been gained by complex test series.



FEM analyses are a valuable tool for optimizing design and functionality - to the benefit of the user.

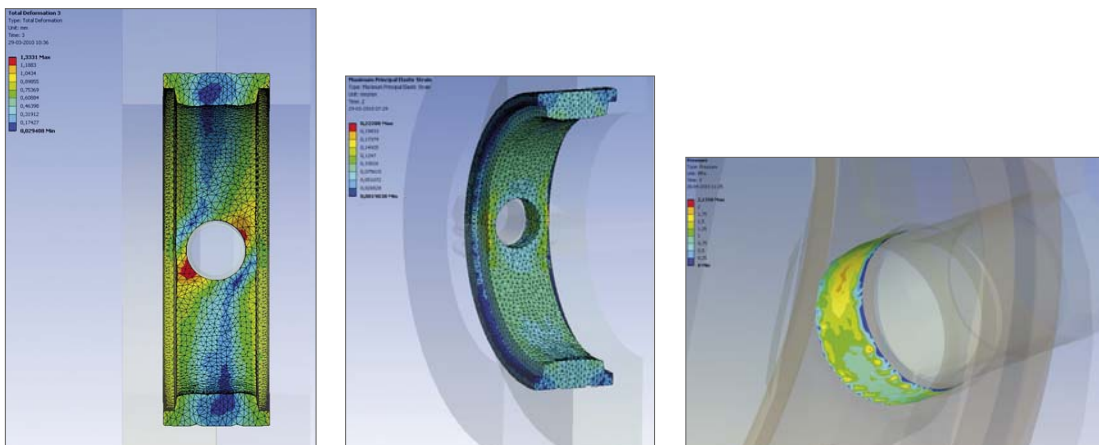

Connection types



Welding end



DIN male part



DIN Liner/groove nut



Clamp



RJT male part



IDF male part



SMS male part



SMS Liner/groove nut



Intermediate flange
(VARIVENT®)



T-smart Butterfly Valves

Optional equipment

- Manual actuator with one or two feedback signals
- Scissors-type manual actuator, can be set to/locked in 7 different positions
- Manual actuator, infinitely variable/lockable
- Pneumatic actuator with limit stop, adjustable
- Pneumatic actuator with two-position cylinder, adjustable
- T-smart butterfly valves for ATEX applications
- Other additional equipment on request

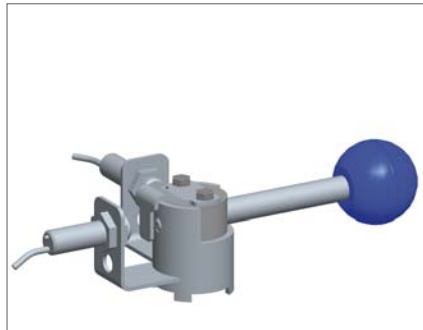
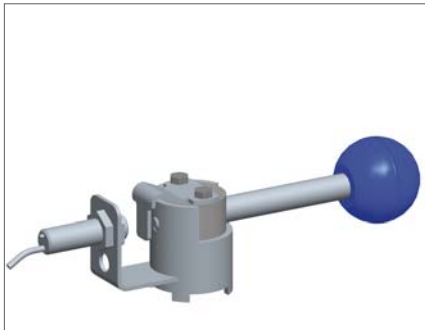

Manual actuator with one or two feedback signals



Scissors-type manual actuator

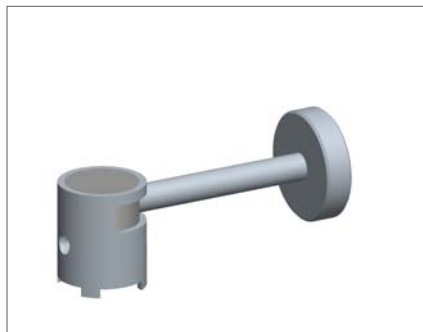

Manual actuator, stepless



Quality and process reliability – highly important characteristics and standard for all products made by GEA Tuchenhagen.

Highest hygienic design requirements, favorable flow properties and gentle product handling, selection of top-grade materials, high-grade surfaces and extensive and thorough testing for suitability for practical use are the distinguishing features of the T-smart butterfly valves.

T-smart butterfly valves are manufactured in accordance with the highest quality standards. This is ensured by GEA Tuchenhagen's quality assurance system, which is certified according to DIN ISO 9001. Constant quality testing in the workshop, marking of all components, function and leak tests are among the features that ensure a constantly high quality level and enable reliable tracing if spares are required.



T-smart butterfly valves are certified by EHEDG. By issuing the certificate, the test institute confirms that the T-smart butterfly valve has superior hygienic properties and optimum CIP-capability in accordance with EHEDG standards.

T-smart Mixproof Butterfly Valves

For decades, GEA Tuchenhagen has been one of the leading suppliers of top-grade valve technology for the separation of media. With the T-smart mixproof butterfly valve, GEA Tuchenhagen now offers another media separation valve variant.

Main features

- Cost-effective leakage protection
- "Single disc" valve concept
- Hygienic design of the leakage cavities, easy to clean
- Compact design (with intermediate flange)
- Sealing material EPDM, or FKM
- Low switching loss (minimum leakage cavity volume)
- Easy handling for maintenance and service



Design and features

T-smart mixproof butterfly valves are characterized by their modular design. The actuator systems used are of the same type as on the T-smart butterfly valve. Thanks to the modular design, conversion from manual to pneumatic actuator is also quite easy for this type of valve.

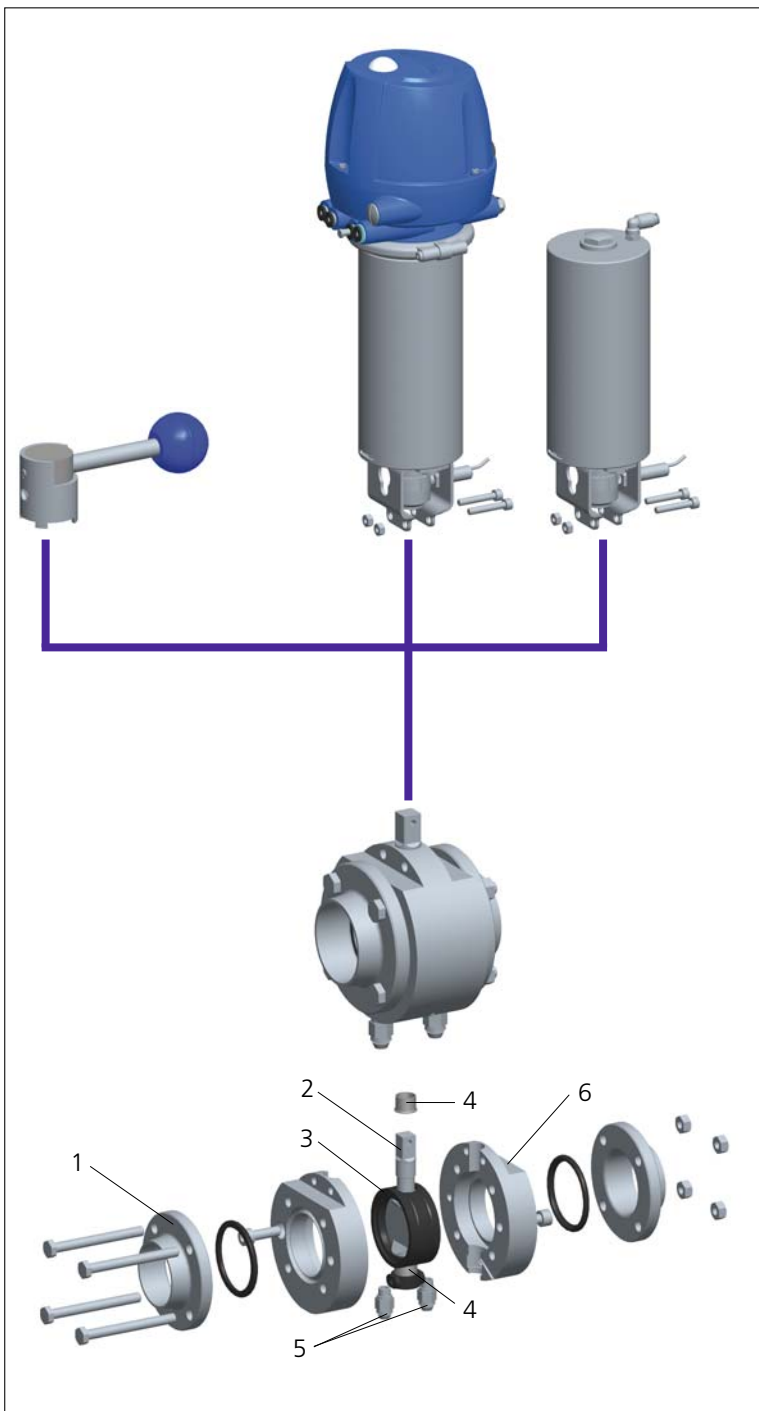

Product features at a glance:

1. Housing flanges with precision-made seal seat geometries
2. Valve disk made of solid material with high-grade surface finish (no waste-wax casting)
3. Sealing materials EPDM, or FKM, FDA-conform, low switching moment, low wear and vacuum resistant
4. Valve disk shafts run in friction bearings
5. Leakage connections for medium draining, leakage indicator or leakage cavity flushing
6. With intermediate flange type 8881/8880 with short, compact design, concealed screws (easy to clean) and proven VARIVENT® flange connection technology

T-smart Mixproof Butterfly Valves

Fields of application

The T-smart mixproof butterfly valve as a process element for the separation of media is suitable for a variety of applications:

- In CIP systems, for separating CIP media
- In flush-out processes
- In water management
- As pipe section shut-off valve for separating media
- In CIP/gas management (breweries)
- At storage tanks for separating product/CIP
- As CIP return valve in a valve matrix

Preferably suitable for liquid and gaseous media without suspended matter/particles.

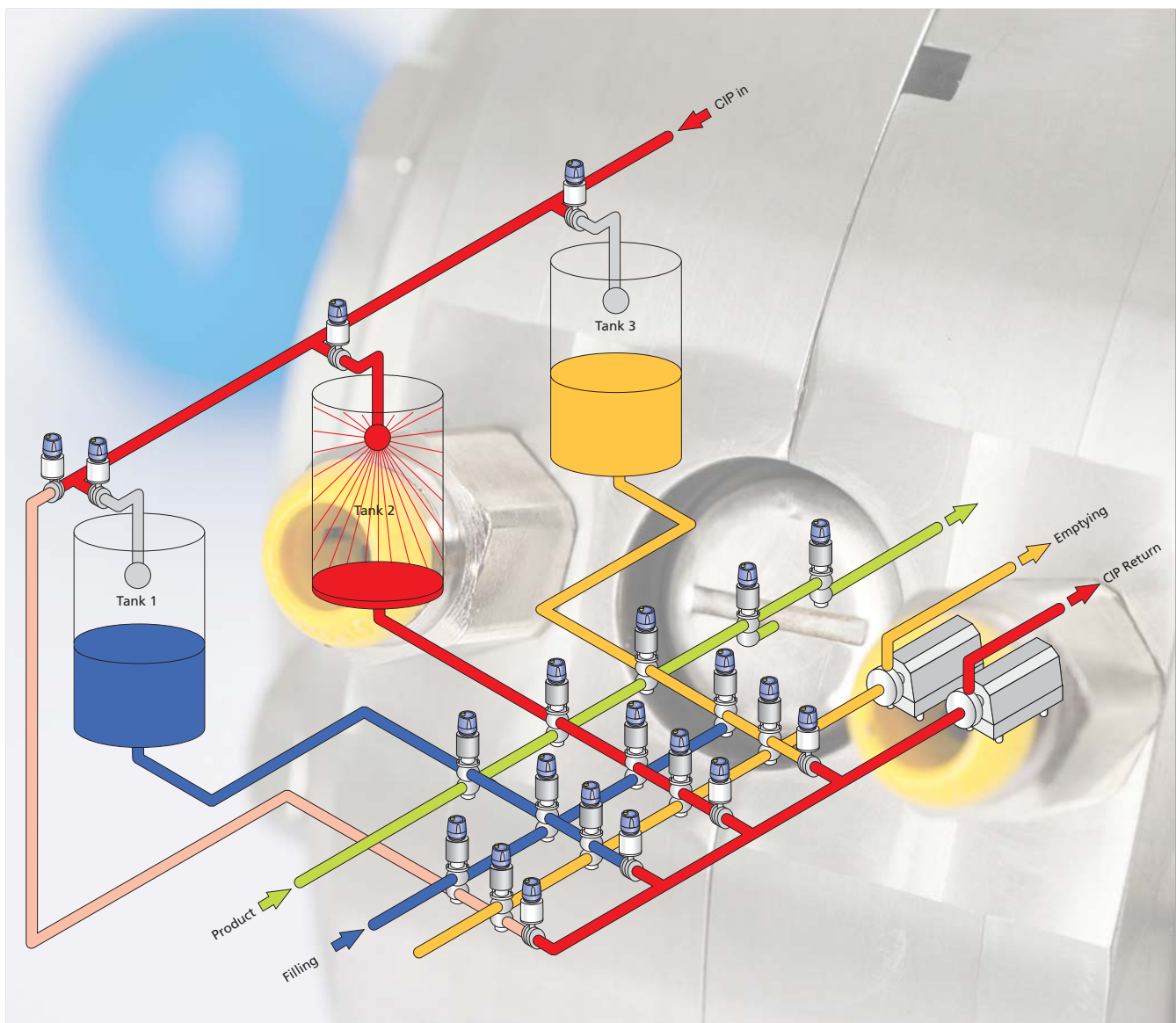

Function of the T-smart mixproof butterfly valve

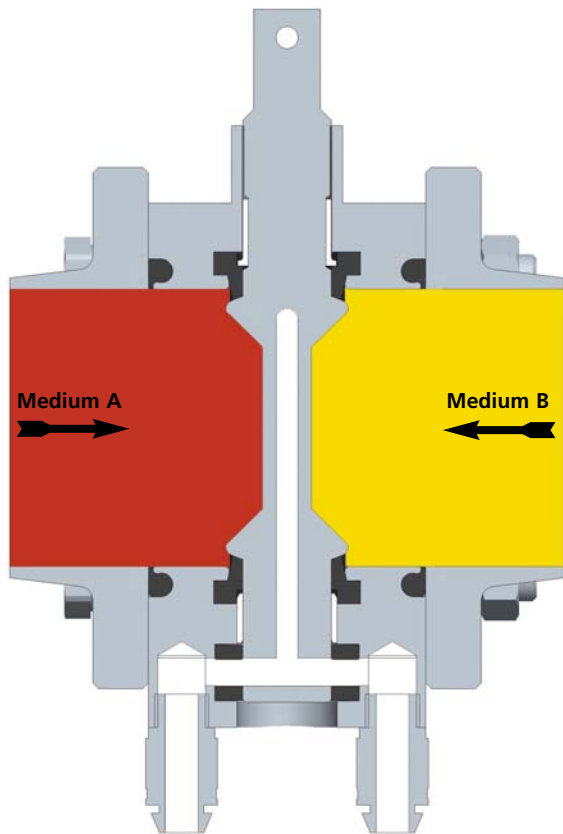

Closed valve position

When the valve is in the non-actuated position (OFF position), medium A and medium B are reliably separated. The leakage cavity is open towards the atmosphere in this case. After switching, the medium in the valve disk leakage areas can drain by gravity (1). The connections also serve as leakage indicators.

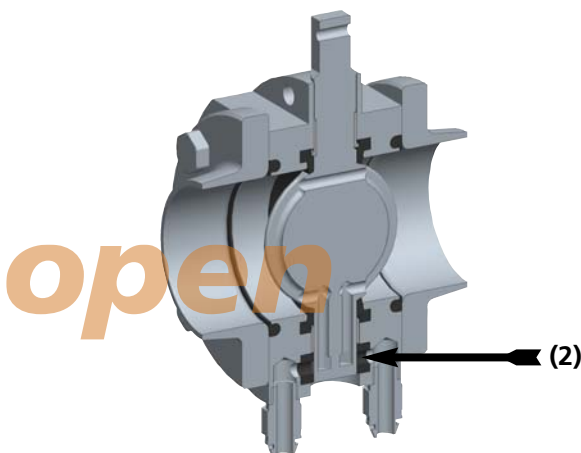

Open valve position

In the open valve position, the leakage paths towards the atmosphere are closed.

Sealing takes place at the short valve disk shaft (2).

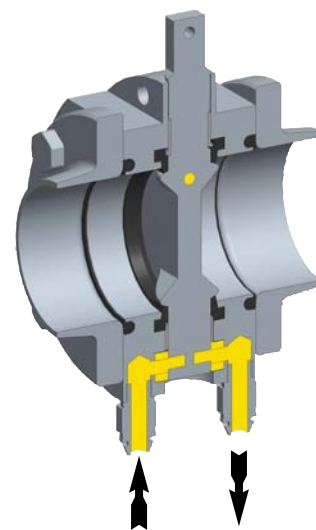

Cleaning of the leakage cavity

The leakage paths can be cleaned/flushed if necessary. For this purpose, the two cleaning connections can be integrated into the CIP circuit. Flushing must take place when the valve is closed. The cleaning pressure in the supply line should be slightly smaller than the inside process pressure (hygienic aspects).

Technical Data

Materials

Product wetted parts

Housings and flanges

T-smart butterfly valves 1.4301 (AISI 304),

or 1.4404 (AISI 316L)

T-smart mixproof butterfly valves 1.4404 (AISI 316L)

Butterfly valve disk 1.4404 (AISI 316L)

Non product wetted parts 1.4301 (AISI 304)

Surface finish

Product-wetted parts: $Ra \leq 0.8 \mu m$,

Non product wetted parts: metal blank

Seals

T-smart butterfly valves:

EPDM (FDA), HNBR (FDA), FKM (FDA),

VMQ/silicone (FDA)

T-smart mixproof butterfly valves:

EPDM (FDA), FKM (FDA)

Temperature range:

EPDM -40 °C ... +135 °C (briefly +150°C/during sterilization)

HNBR -25 °C ... + 125 °C

FKM -10 °C ... + 150 °C

VMQ -40 °C ... + 150 °C

Operating pressure max. 10 bar (145 psi)

Control air min. 4.8 bar (70 psi),
max. 8 bar (116 psi)

Pipe classes and nominal widths

Metric

Outside diameter acc. to DIN 11850, series II, DIN 11866, series A

T-smart butterfly valves: DN 25 - DN 150

T-smart mixproof butterfly valves: DN 50 - DN 100

Inch OD

Outside diameter acc. to BS 4825 Part I DIN 11866, series C

T-smart butterfly valves: 1" - 4"

T-smart mixproof butterfly valves: 2" - 4"

Installation position

T-smart butterfly valves:

Any position

T-smart mixproof butterfly valves:

Installation only in horizontal pipes,
actuator vertically upright

DIN ISO 9001 / EN 29001

T-smart butterfly valves are in compliance with FDA,
LMBG 4/94 and EN 93

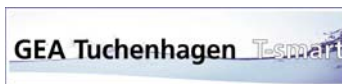

GEA Mechanical Equipment

GEA Tuchenhagen GmbH

Am Industriepark 2-10, 21514 Büchen, Germany

Phone +49-4155 49-0, Fax +49-4155 49-2423

sales.geatuchenhagen@geagroup.com, www.tuchenhagen.com